



Air velocity sensor

QVM62.1

Use

This sensor is used to control the air velocity to a constant value, or to balance out pressure fluctuations (supply or extract air control), or to monitor the flow in air ducts. It primarily is used for modulating fan control in primary plants to set the basic volume flow.

Action

The QVM62.1 records the air velocity as a measured value and converts it to an active DC 0...10 V or 4...20 mA output signal.

Three measuring ranges are available:

0...5 m/s, 0...10 m/s, and 0...15 m/s.

The sensor measures a point, i.e., it measures the values at a specific location in the flow profile. For recording the mean air velocity in the duct, the sensor's immersion depth is the key measure. The immersion depth depends on the flow profile.

The measurement principle is based on the anemometric measurement principle.

The specially developed thin film sensing element of the QVM62.1 is to a big extend independent from the flow direction and is nearly insensitive to any kind of dirt in the airflow.

Ordering

When ordering, indicate the name and type designation :

Air velocity sensor **QVM62.1**

The air velocity sensor consists of:

- Immersion stem with sensor head and sensing element
- Extension pipe with fitting
- Immersion stem end with flow direction arrow
- Adjustable connecting flange
- Transducer
- Connection cable, screened, four-core, 1 m long

A scale with 0.5 cm grating on the immersion stem and the extension pipe indicates the immersion depth.

The connecting flange is used to attach and seal the immersion stem on the duct wall.

A plastic housing with removable cover accommodates the transducer. It can be screwed to a flat surface.

The sensor cable is connected; the sensor and the transducer together represent a unit. The measuring ranges are selected by inserting or removing a plug-in jumper.

- Protection against false wiring is provided related to own voltages, i.e., measuring output X1 is short-circuit proof.

The sensor head connections are not protected against AC/DC 24 V operating voltage.

Wiring and setting elements

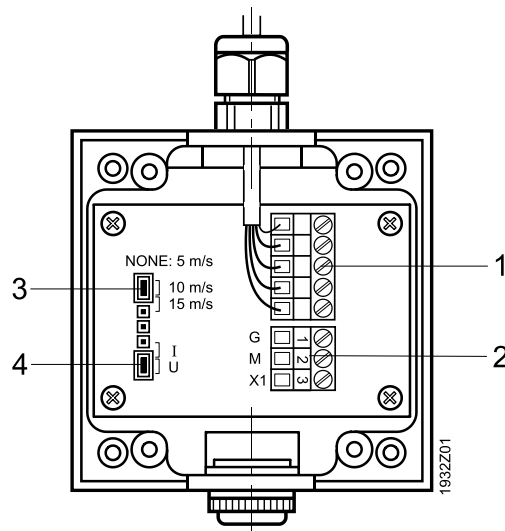

- 1 Terminal block for connection to the immersion stem
- 2 Terminal block for connection to controller
- 3 Plug-in unit for setting the three velocity ranges. The following applies:
 No plug-in jumper = 0...5 m/s
 Plug-in jumper on 1 and 2 = 0...10 m/s (factory setting)
 Plug-in jumper on 2 and 3 = 0...15 m/s
- 4 Terminal block for selection of the output signal:
 Pos I = DC 4...20 mA
 Pos U = DC 0...10 V

Disposal



The devices are considered electronics devices for disposal in terms of European Directive 2012/19/EU and may not be disposed of as domestic waste.

- Dispose of the device via the channels provided for this purpose.
- Comply with all local and currently applicable laws and regulations.

Technical data

Power supply	Operating voltage	AC/DC 24 V \pm 20 % (SELV)
	Frequency	50/60 Hz
	Power consumption	\leq 5 VA (max. 200 mA)
	External supply line protection	Fuse slow max. 10 A or Circuit breaker max. 13 A Characteristic B, C, D according to EN 60898 or Power source with current limitation of max. 10 A
Measuring data	Measuring ranges, adjustable	0...5 m/s 0...10 m/s (factory setting) 0...15 m/s
	Measuring accuracy at 20 °C, 45 % r.h., 1013 hPa	
	0...5 m/s	\pm (0.2 m/s + 3 % of measured value)
	0...10 m/s	\pm (0.2 m/s + 3 % of measured value)
	0...15 m/s	\pm (0.2 m/s + 3 % of measured value)
	Permissible air velocity	20 m/s
Signal output X1	Direction dependence	<0.3 % of measured value at $<\pm 10^\circ$
	Time constant t_{90} at 10 m/s	ca. 4 s
	Voltage output	DC 0...10 V, ± 1 mA
Line length	Current output	DC 4...20 mA, 0...500 Ω
	Perm. line length to controller at	
	0.6 mm dia copper cable	50 m
	1 mm ² copper cable	150 m
Connections	1.5 mm ² copper cable	300 m
	Line length to the sensor head	1 m (prewired)
	Mechanical:	screw connection
Degree of protection	Electric:	screw terminal, max. 2 \times 1.5 mm ²
	Protection class	III according to EN 60730-11
	Protection degree of housing	
Environmental conditions	Transducer	IP42 according to EN 60529
	Sensor head	IP20 according to EN 60529
	Operation (transducer and immersion stem)	IEC 721-3-3
	Climatic conditions	class 3K5
	Temperature	-10...+45 °C
	Humidity (non-condensing)	<95 % r.h.
	Mechanical conditions	class 3M2
	Chemical conditions	class 3C2
	Storage (transducer and immersion stem)	IEC 721-3-1
	Climatic conditions	class 1K3
	Temperature	-30...+60 °C
	Humidity (non-condensing)	<95 % r.h.
	Mechanical conditions	class 1M2
	Transport (transducer and immersion stem)	IEC 721-3-2
Climatic conditions	class 2K3	
Temperature	-25...+60 °C	
Humidity (non-condensing)	<95 % r.h.	
Mechanical conditions	class 2M2	

Materials and colours	Housing bottom	polycarbonat, RAL 7001 (silver-grey)
	Housing cover	polycarbonat, RAL 7035 (light-grey)
	Sensor pipes	polycarbonat, RAL 7001 (silver-grey)
	Sensor head, extension, end	polycarbonat, RAL 7035 (light-grey)
	Connecting flange	polycarbonat, RAL 7001 (silver-grey)
Standards, directives and approvals	Sensor, total	silicon-free
	Product standard	EN 60730-1 Automatic electrical controls for household and similar use
	Electromagnetic compatibility (Applications)	For use in residential, commerce, light-industrial and industrial environments
	EU Conformity (CE) EAC Conformity	CM2T1932xx ^{*)} Eurasia conformity ⁾
Environmental compatibility	The product environmental declaration CM1E1932 ^{*)} contains data on environmentally compatible product design and assessments (RoHS compliance, materials composition, packaging, environmental benefit, disposal).	
Weight	With packaging	0.352 kg

*) The documents can be downloaded from <http://siemens.com/bt/download>.

Engineering notes

Place the sensor on the measuring path in a location where the air flow is quiet. Thus: do not place it close to dampers, registers, and duct direction changes.

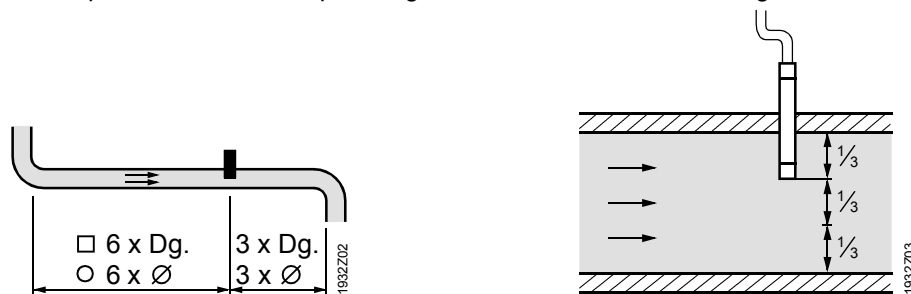

Use a transformer with safety extra-low voltage (SELV) with separate winding for 100% ON-time. Observe all local safety rules and regulations pertaining to sizing and protecting transformers.
Note the permissible line length to the controller.

Mounting and installation notes

Mount the immersion stem so that the air flows through the opening at the sensor head. The immersion stem is premounted and wired to the transducer on delivery. The sensor pipes and the end with the direction arrow are prearranged on the connecting cable-fit them together (use the direction-oriented snap-on connections). If the extension pipe is not required, remove it from the cable. The connecting flange is not attached on delivery.

The sensor is supplied with mounting instructions.

Commissioning notes

Check the wiring and the air velocity range settings prior to commissioning.
Check the immersion stem position in the air duct (mounting instructions!).

Diagrams

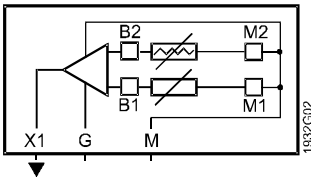

- G Operating voltage AC/DC 24 V
- M Measuring neutral/ operating voltage ground
- X1 Output signal DC 0...10 V or 4...20 mA

Dimensions (All dimensions in mm)

